

Flex-C Trac & Flex-C Angle w/Hammer-Lock



Using the patented technology of the Flex-C Trac system, builders are able to create high quality curved walls, columns, arches and even "S"-curves in a simple, easy to use product. Labor costs are reduced because using Flex-C Trac and Flex-C Angle is fast and as easy as 1, 2, 3.

First, bend the track or angle to the desired position. The pivotal sections make it easy to create the perfect curve with no uneven or flat spots.

Second, on a hard surface, such as concrete, hammer the Hammer-Lock tabs to embed them into the web. This secures the shape. For added strength, install self-tapping screws into the side of the Flex-C Trac or Flex-C Angle.

Finally, fasten the track or angle to the floor or ceiling. This secured span of steel provides for a strong, solid installation.

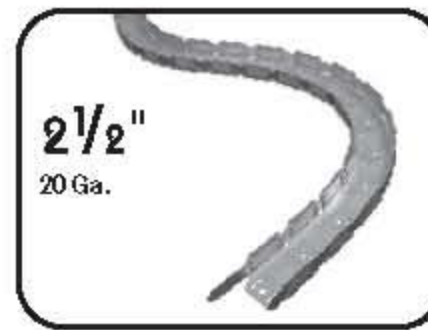

2 1/2"
20 Ga.

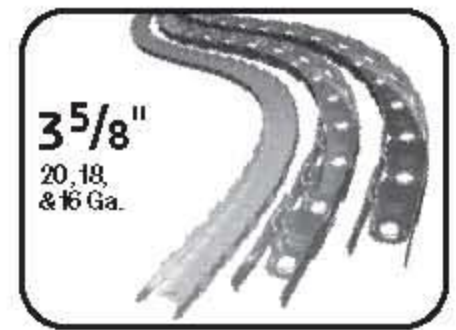

3 5/8"
20, 18,
& 16 Ga.

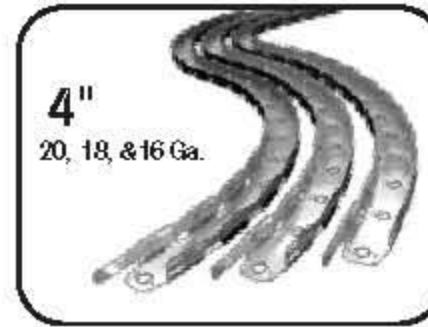

4"
20, 18, & 16 Ga.

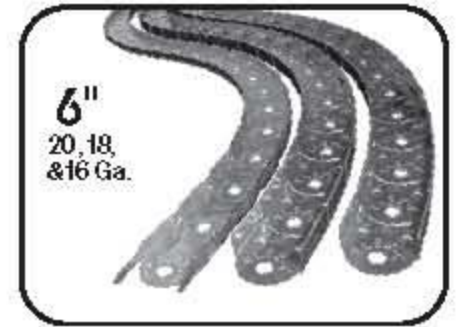

6"
20, 18,
& 16 Ga.



8" & 10"
20, 18, & 16 Ga.



Flex-C
Angle
20, & 16 Ga.

Dimensions			Minimum Radius
Flex-C Trac	X (Web)	Y (Leg)	
2 1/2", 20 Ga.	2 1/2"	1 1/8"	7"
3 5/8", 20 Ga.	3 5/8"	1 1/8"	7"
3 5/8", 18 & 16 Ga.	3 5/8"	2"	10 1/2"
4", 20, 18 & 16 Ga.	4"	2"	12 3/4"
6", 20 Ga.	6"	1 1/4"	18"
6", 18 & 16 Ga.	6"	2"	18"
8", 20, 18 & 16 Ga.	8"	2"	40"
10", 20, 18 & 16 Ga.	10"	2"	45"
Flex-C Angle 20 Ga.	2 1/4"	1 1/8"	7"
Flex-C Angle 16 Ga.	3 5/8"	2"	10 1/2"

Length of all members: 10'

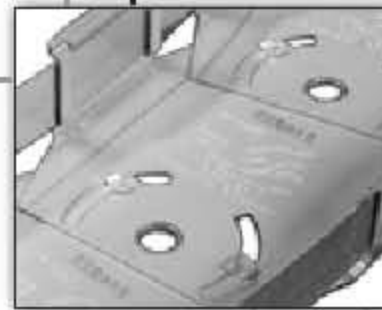

SPECIFICATIONS

Channel

20 Gauge Track & Angle:

- ASTM A653, Structural Grade 33, Hot dipped galvanized steel.
- Standard protective coating equal or superior to ASTM A653 coating designation A-40 or G-40.

18 Gauge and 16 Gauge Track & Angle:

- ASTM A653, Structural Grade 50, Hot dipped galvanized steel.
- Standard protective coating equal or superior to ASTM A653 coating designation G-60.

Strap

With 20 Gauge Track & Angle:

- ASTM A653, hot dipped galvanized steel.
- Standard protective coating equal or superior to ASTM A653 coating designation G-60.
- Dimensions: .750" x .023"
- Structural Grade 80

With 18 Gauge and 16 Gauge Track & Angle:

- The specifications for strap are the same as the channel with 18 gauge and 16 gauge thickness.

SECTIONAL VIEWS

FLEX-C TRAC

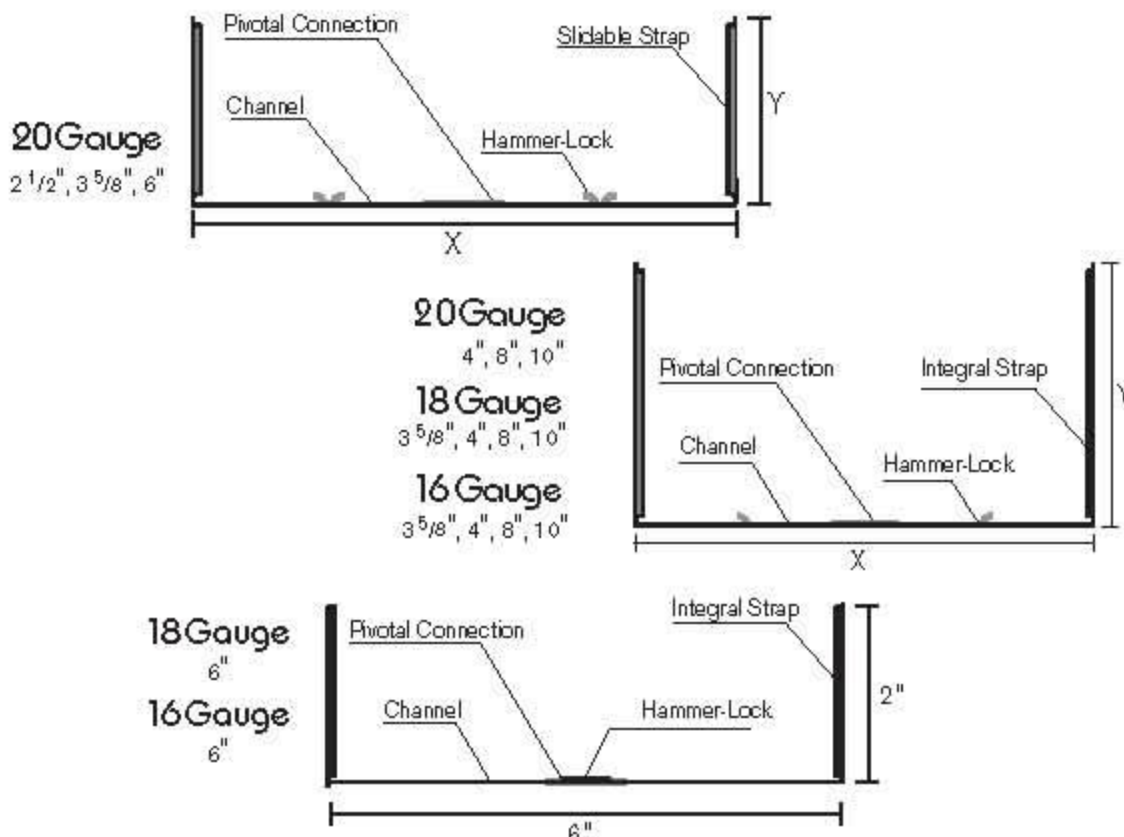

FLEX-C ANGLE

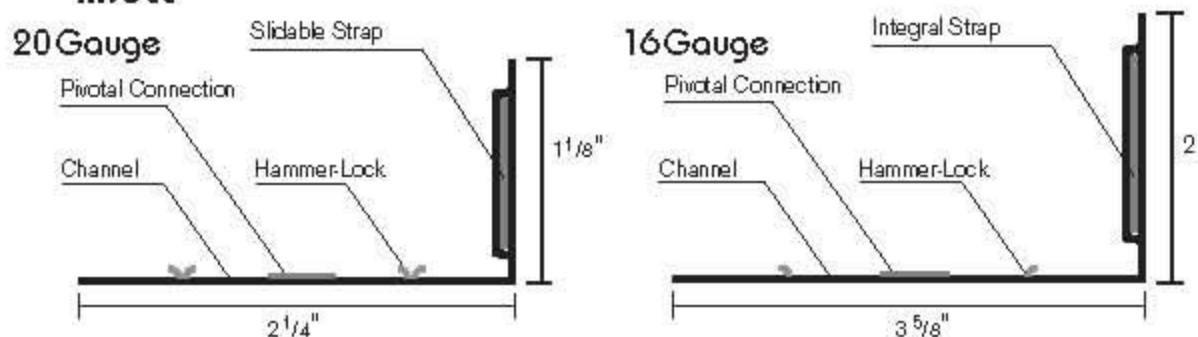

631-749-3313 Fax 631-749-3356

PART 1 – GENERAL

1.1 DESCRIPTION

- A. Scope of Work All interior and exterior load-bearing and non load-bearing light gage steel and wood studs, track, joists, trusses, bridging and related accessories are as indicated on the Contract Drawings and specified herein.
- B. Related work specified elsewhere.

1.2 SUMMARY

- A. This Section includes the following:
 1. Exterior and Interior non load-bearing walls.
 2. Exterior and Interior load-bearing walls.

1.3 PERFORMANCE REQUIREMENTS

- A. Engineering Responsibility: Engage a fabricator who assumes undivided responsibility for engineering FLEX-C TRAC and FLEX-C ANGLE metal framing by employing a qualified professional engineer to prepare design calculations, shop drawings, and other structural data.
- B. Design exterior non load-bearing curtainwall framing to accommodate lateral deflection without regard to contribution of sheathing materials.
- C. All Exterior and Interior load-bearing applications are to be engineered by a qualified professional Engineer.

1.4 QUALITY ASSURANCE

- A. Installer Qualifications: Engage an experienced Installer who has completed cold-formed metal framing similar in material, design, and extent to that indicated for this project and with a record of successful in-service performance.
- B. Standard
 1. Work shall meet the requirements of the following standards:
 - a. American Iron and Steel Institute (A.I.S.I.) "Design of Cold Formed Steel Structural Members," 1986 with 1989 amendments.
 - b. American Welding Society (A.W.S.) D.1.3, 1981 "Structural Welding Code – Sheet Steel"
 - c. American Society for Testing Materials (A.S.T.M.)
 - d. American Institute of Steel Construction (A.I.S.C.) "Manual of Steel Construction," 9th edition.
 - e. All pertinent Federal, State, and Local codes.
 2. The most stringent requirements shall govern in conflicts between specified codes and standards.
 3. Certify that each welder has satisfactorily passed AWS qualification tests for welding processes involved and, if pertinent, has undergone recertification within the past twelve months.
- C. Inspection
 1. As directed by Architect, Owner's testing agency may inspect the maintenance of a quality control program including spot checking weldments and welding procedures in accordance with A.W.S. standards.
 2. Full responsibility for quality control shall remain with the Contractor.

1.5 DELIVERY, STORAGE, AND HANDLING

- A. Protect FLEX-C TRAC and FLEX-C ANGLE metal framing from corrosion, deformation, and other damage during delivery, storage, and handling.
- B. Store FLEX-C TRAC and FLEX-C ANGLE metal framing, protect with waterproof covering, and ventilate to avoid condensation.

1.6 SUBMITTALS

- A. Structural Calculations
 1. Submit structural calculations prepared by the Professional Engineer of record. Calculations shall include, but are not limited to:
 - a. Description of design criteria.
 - b. Engineering analysis depicting stress and deflection (stiffness) requirements for each framing application.
 - c. Selection of framing components and accessories.
 - d. Verification of attachments to structure and/or adjacent framing components.
- B. Drawings
 1. Submit drawings prepared by the manufacturer for approval by the Project Architect and Engineer. These drawings should include:
 - a. Cross-sections, plans and/or elevations depicting component locations.
 - b. Connection details showing screw types and locations, weld lengths and locations or other related fastener requirements.
 - c. Where the Contractor intends on erecting prefabricated/prefinished panels, drawings depicting panel configurations, dimensions and locations would be developed by the Contractor.

PART 2- PRODUCTS

2.1 AVAILABLE MANUFACTURERS:

- A. Manufacturers offering FLEX-C TRAC and FLEX-C ANGLE metal framing that may be incorporated in the work include, and are limited to, the following:
 1. FLEX-ABILITY CONCEPTS - 5500 SW 36th St, Oklahoma City, OK 73179 (405) 996.5343 (FAX) 996.5353 www.flexabilityconcepts.com

2.2 MATERIALS

- A. Galvanized – 20 Gauge Steel Sheet Track: ASTM A 653, and as follows:
 1. Coating Designation: Galvanized Steel equal or superior to ASTM A653 G40 or A40
 2. Grade: 33
- B. Galvanized – 18 Gauge and 16 Gauge Steel Sheet Track: ASTM A653, and as follows:
 1. Coating Designation: Galvanized or Galvanized Steel equal or superior to ASTM A653 G60.
 2. Grade: 50
- C. Galvanized Sliding Steel Strap: ASTM A653
 1. Coating Designation: Galvanized Steel equal or superior to ASTM A653 G60.
 2. Grade: 80
- D. Galvanized Integral Steel Strap: ASTM A653:
 1. Coating Designation: Galvanized Steel equal or superior to ASTM A653 G60.
 2. Grade: 50

2.3 WALL FRAMING

- A. Steel Studs: Manufacturer's standard C-shaped steel studs with punched webs in depths indicated, with lipped flanges 1-5/8 inches in width. Design uncoated-steel thickness of specified gauge unless noted otherwise
- B. Wood Studs: Per applicable drawing specifications.
- C. FLEX-C TRAC: Manufacturer's standard C- shaped flexible steel track with banded flanges and screw attachments at every flange interval.
- D. FLEX-C ANGLE: Manufacturer's standard L-shaped flexible steel angle with banded flanges and screw attachments at every flange interval.

2.4 FRAMING ACCESSORIES

- A. Fabricate steel-framing accessories of the same material and finish used for framing members; with a minimum yield strength of 33,000 psi.
- B. Provide accessories of manufacturer's standard thickness and configuration, unless otherwise indicated.

2.5 FASTENERS

- A. Mechanical Fasteners: Corrosion-resistant coated, self-drilling, self-threading steel drill screws.
 1. Head Type: Low-profile head beneath sheathing, manufacturer's standard elsewhere.
- B. Welded Electrodes: Comply with AWS standards.

2.6 MISCELLANEOUS MATERIALS

- A. Galvanizing Repair Paint: SSPC-Paint 20 of DOD-P-21035, with dry film containing a minimum of 94 percent zinc dust by weight.

2.7 FABRICATION

- A. Fabricate FLEX-C TRAC and FLEX-C ANGLE metal framing and accessories plumb, square, true to line, true to radius, and with connections securely fastened, according to manufacturer's recommendations and the requirements of this Section.
 1. Fabricate assemblies in jig templates or free form scribed radiuses.
 2. Extreme care should be taken when handling or cutting any metal products. Observe all safety precautions when handling or cutting Flex-C Trac.
 3. Cut FLEX-C TRAC and FLEX-C ANGLE metal framing by sawing or shearing; do not torch cut.
 4. Fasten FLEX-C TRAC metal framing by welding or screw fastening, as standard with fabricator. Wire tying of FLEX-C TRAC and FLEX-C ANGLE framing members is not permitted.
 - a. Comply with AWS requirements and procedures for welding, appearance and quality of welds, and methods used in correcting welding work
 - b. Locate mechanical fasteners and install according to FLEX-C TRAC and FLEX-C ANGLE manufacturer's instructions with screw penetrating banding at every flange interval and joined members by not less than 3 exposed screw threads.
 5. Fasten other materials to FLEX-C TRAC and FLEX-C ANGLE metal framing by welding, bolting, or screw fastening, according to manufacturer's recommendations.
- B. Reinforce, stiffen, and brace framing assemblies to withstand handling, delivery, and erection stresses. Lift fabricated assemblies to prevent damage or distortion.
- C. Fabrication Tolerances: Fabricate assemblies as required.

PART 3- EXECUTION

3.1 INSTALLATION, GENERAL

- A. FLEX-C TRAC and FLEX-C ANGLE metal framing may be shop or field fabricated for installation, or it may be field assembled.
- B. Install FLEX-C TRAC and FLEX-C ANGLE metal framing and accessories plumb, square, true to line, true to radius, and with connections securely fastened, according to manufacturer's recommendations and the requirements of this Section.
 1. Extreme care should be taken when handling or cutting any metal products. Observe all safety precautions when handling or cutting Flex-C Trac.
 2. Cut FLEX-C TRAC and FLEX-C ANGLE members by sawing or shearing; do not torch cut
 3. Fasten FLEX-C TRAC and FLEX-C ANGLE members by welding or screw fastening, as standard with fabricator. Wire tying of FLEX-C TRAC and FLEX-C ANGLE members is not permitted.
 - a. Comply with AWS requirements and procedures for welding, appearance and quality of welds, and methods used in correcting welding work.
 - b. Locate mechanical fasteners and install according to FLEX-C TRAC and FLEX-C ANGLE manufacturer's instructions with screw penetrating banding at every flange interval and joined members by not less than 3 exposed screw threads.
 - C. Install FLEX-C TRAC and FLEX-C ANGLE members in one or multi-piece lengths as specified.
 - D. Splice FLEX-C TRAC and FLEX-C ANGLE segments by overlapping bands from one FLEX-C TRAC or FLEX-C ANGLE to another and attaching screwed fasteners at overlapping plates or flange intervals. Screw penetrations of not less than 3 exposed screw threads.
 - E. Provide temporary bracing and leave in place until framing is permanently stabilized.
 - F. Do not bridge building expansion and control joints with FLEX-C TRAC or FLEX-C ANGLE metal framing. Independently frame both sides of joints.
 - G. Fasten reinforcement plate over web penetrations that exceed size of manufacturer's standard punched openings.

3.2 REPAIRS AND PROTECTION

- A. Galvanizing Repairs: Prepare and repair damaged galvanized coatings on fabricated and installed FLEX-C TRAC and FLEX-C ANGLE metal framing with galvanizing repair paint according to ASTM A 780 and the manufacturer's instructions.
- B. Touchup painting: Wire brush, clean, and paint scarred areas, welds, and rust spots on fabricated and installed prime-painted, FLEX-C TRAC and FLEX-C ANGLE metal framing.
 1. Touchup painted surfaces with same type of shop paint used on adjacent surfaces.
- C. Provide final protection and maintain conditions in a manner acceptable to manufacturer and installer to ensure that FLEX-C TRAC and FLEX-C ANGLE metal framing is without damage or deterioration at the time of substantial completion.